



MAX3668 Evaluation Kit

General Description

The MAX3668 evaluation kit (EV kit) is an assembled, surface-mount demonstration board that provides easy optical or electrical evaluation of the MAX3668. Although the MAX3668 evaluation kit is shipped in the electrical configuration, this data sheet also provides configuration instructions for optical operation.

Component Suppliers

SUPPLIER	PHONE	FAX
AVX	803-946-0690	803-626-3123
Coilcraft	847-639-6400	847-639-1469
Murata	814-237-1431	814-238-0490
Zetex	516-543-7100	516-864-7630

Note: Please indicate that you are using the MAX3668 when contacting these component suppliers.

Component List for Electrical Configuration

DESIGNATION	QTY	DESCRIPTION
C1, C17	2	0.01 μ F, 10% ceramic capacitors (0402)
C2, C6, C20	3	0.01 μ F, 10% ceramic capacitors (0603)
C3	1	0.1 μ F, 10%, 25V min ceramic capacitor (0603)
C4, C7, C10, C11	4	1 μ F ceramic capacitors (0805)
C8	1	100pF, 10% ceramic capacitor (0402)
C16	1	0.1 μ F, 10%, 25V min ceramic capacitor (0805)
C19	1	10 μ F, 10%, 16V min tantalum capacitor AVX TAJC106K016
C21	1	5pF, 10% ceramic capacitor (0402)
CR1	1	LED
J1, J2, J5	3	SMA connectors (edge mount)
L3	1	3.3 μ H inductor Coilcraft 1008CS-332XKBC
P1	1	2-pin header (0.1" center)
P1	1	Shunt
Q1	1	PNP transistor Zetex FMMT591
R1, R2, R3	3	1k Ω \pm 5% resistors (0603)
R5	1	12.3 Ω \pm 1% resistor (0402)
R6, R7	2	84.5 Ω \pm 1% resistors (0603)
R8, R9	2	124 Ω \pm 1% resistors (0603)
R10, R11	2	20 Ω \pm 1% resistors (0603)

Features

- ◆ Fully Assembled and Tested
- ◆ +3.3V to +5.0V Operation
- ◆ Input Termination Provided On-Board
- ◆ Independent Electrical Monitoring of Modulation and Bias Currents

Ordering Information

PART	TEMP. RANGE	IC PACKAGE
MAX3668EVKIT	-40°C to +85°C	32 TQFP

Evaluates: MAX3668

DESIGNATION	QTY	DESCRIPTION
R12	1	10 Ω \pm 1% resistor (0402)
R13, R20, R22, R25	4	0 Ω resistors (0603)
R14, R15, R16	3	50k Ω variable resistors
R18	1	110 Ω \pm 5% resistor (0603)
R21	1	10 Ω \pm 5% resistor (0603)
R23	1	15 Ω \pm 5% resistor (0805)
R24	1	1.5k Ω \pm 5% resistor (0603)
VCC, GND, TP1, TP4, TP5, TP6, TP9, TP10	8	Test points
U1	1	MAX3668EHJ (32 TQFP)
U3	1	MAX495CSA (8-pin SO)

Component Modifications for Optical Configuration

DESIGNATION	QTY	DESCRIPTION
J5	1	Remove
L2	1	3.3 μ H inductor Coilcraft 1008CS-332XKBC
R5	1	Remove
R13	1	Remove
R19	1	20 Ω \pm 5% resistor (0402)
R20	1	5 Ω \pm 5% resistor (0402)
R22	1	Remove
R23	1	Remove
U2	1	User-supplied laser diode



MAX3668 Evaluation Kit

Quick Start

Electrical Setup (Default)

In the electrical configuration, an Automatic Power Control (APC) test circuit is included to emulate a semiconductor laser with a monitor photodiode. Monitor-diode current is provided by Q1, which is controlled by an operational amplifier (U3). The APC test circuit, consisting of U3 and Q1, applies the simulated monitor-diode current (the ratio IBIAS / IMD is $R24 / R23 = 100$) to the MD pin of the MAX3668. To ensure proper operation in the electrical configuration, set up the evaluation board as follows:

- 1) Verify inductor L2 is not installed.
- 2) Remove the shunt from P1 to enable the output.
Note: When performing the following resistance checks, manually set the ohmmeter to a high range to avoid forward biasing the on-chip ESD protection diodes.
- 3) Adjust R14, the MOD potentiometer, for 10k Ω resistance between pins 2 and 3 (test point 5 and ground).
- 4) Adjust R15, the BIAS potentiometer, for 10k Ω resistance between pins 2 and 3 (test point 4 and ground).
- 5) Adjust R16, the APC potentiometer, for 10k Ω resistance between pins 2 and 3 (test point 6 and ground).

- 6) Power-up the board with a +3.3V supply.
- 7) Apply a differential input signal (max amplitude $\leq 800\text{mV}$ per side) to J1 and J2 (DATA+ and DATA-).
- 8) Attach a high-speed oscilloscope with 50 Ω inputs to J5.
- 9) Adjust RBIAS (R15) and RAPC (R16) until the desired laser-bias current is achieved (see note in the *Applications* section of the MAX3668 data sheet).
- 10) Adjust RMOD (R14) until the desired laser-modulation current is achieved.

Optical Setup

For optical operation, the electrical APC test circuit must be disabled. For optical evaluation of the MAX3668, configure the EV kit as described in *Component Modifications for Optical Configuration*.

- 1) Remove the shunt from P1 to enable the output.
- 2) Connect a TO-style header laser and monitor diodes (Figure 1) as follows:
 - Keeping the leads to the laser diode as short as possible, connect the laser diode on the component side of the board between R20 and C17 (VCC) with the cathode connected to R20 and the anode connected to VCC.

Adjustment and Control Descriptions (see Quick Start first)

COMPONENT	NAME	FUNCTION
P1	OUTPUT DISABLE	Enable/Disable the Output Currents. Shunting disables the part. Remove shunt for normal operation.
J5	Electrical Output SMA	Electrical Output. Remove for optical operation.
R14	MOD	Laser Modulation Current Adjustment
R15	BIAS	Laser Bias Current Adjustment. In open-loop mode, R15 adjusts the laser-bias current. In closed-loop operation, R15 adjusts the maximum laser-bias current.
R16	APC	Automatic Power Control Adjustment. For closed-loop operation, R16 adjusts the monitor-diode current level.
TP1	Fail Indicator	TTL Low Level. Indicates a failure in the APC loop.
CR1	Fail Indicator	Refer to the <i>Design</i> section of the MAX3668 data sheet. Set APC current; then increase bias current until LED goes off (LED is illuminated when the APC loop is open and off when the APC loop is closed).

MAX3668 Evaluation Kit

- Connect the monitor diode on the underside of the board with the anode connected to the MD pin of the MAX3668 (underneath the laser-diode cathode) and the cathode connected to V_{CC} (underneath the laser-diode anode).

Note: When performing resistance checks, manually set the ohmmeter to a high range to avoid forward biasing the on-chip ESD protection diodes.

- 4) Adjust R14, the MOD potentiometer, for maximum resistance between pins 2 and 3 (test point 5 and ground).
- 5) Adjust R15, the BIAS potentiometer, for maximum resistance between pins 2 and 3 (test point 4 and ground).
- 6) Adjust R16, the APC potentiometer, for desired optical power. (Refer to the *Design Procedure* section of the MAX3668 data sheet.)
- 7) Power-up the board with a +3.3V supply.
- 8) Apply a differential input signal ($\leq 800\text{mV}$ per side) to J1 and J2 (DATA+ and DATA-).
- 9) Attach the laser diode output to an optical/electrical converter.
- 10) Adjust R15 until the LED, CR1, is no longer illuminated. Laser power can be monitored at the laser diode with an optical/electrical converter (see note in the *Applications Information* section of the MAX3668 data sheet).

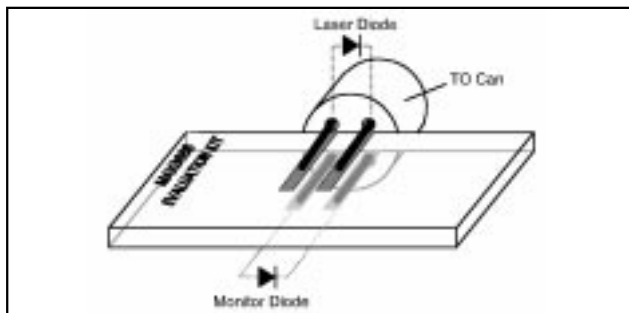

Figure 1. Attachment of Laser Diode/Monitor Diode to MAX3668 EV Kit

- 11) Adjust R14 until the desired optical amplitude is achieved. Optical amplitude can be observed on an oscilloscope connected to an optical/electrical converter.

Evaluates: MAX3668

MAX3668 Evaluation Kit

Evaluates: MAX3668

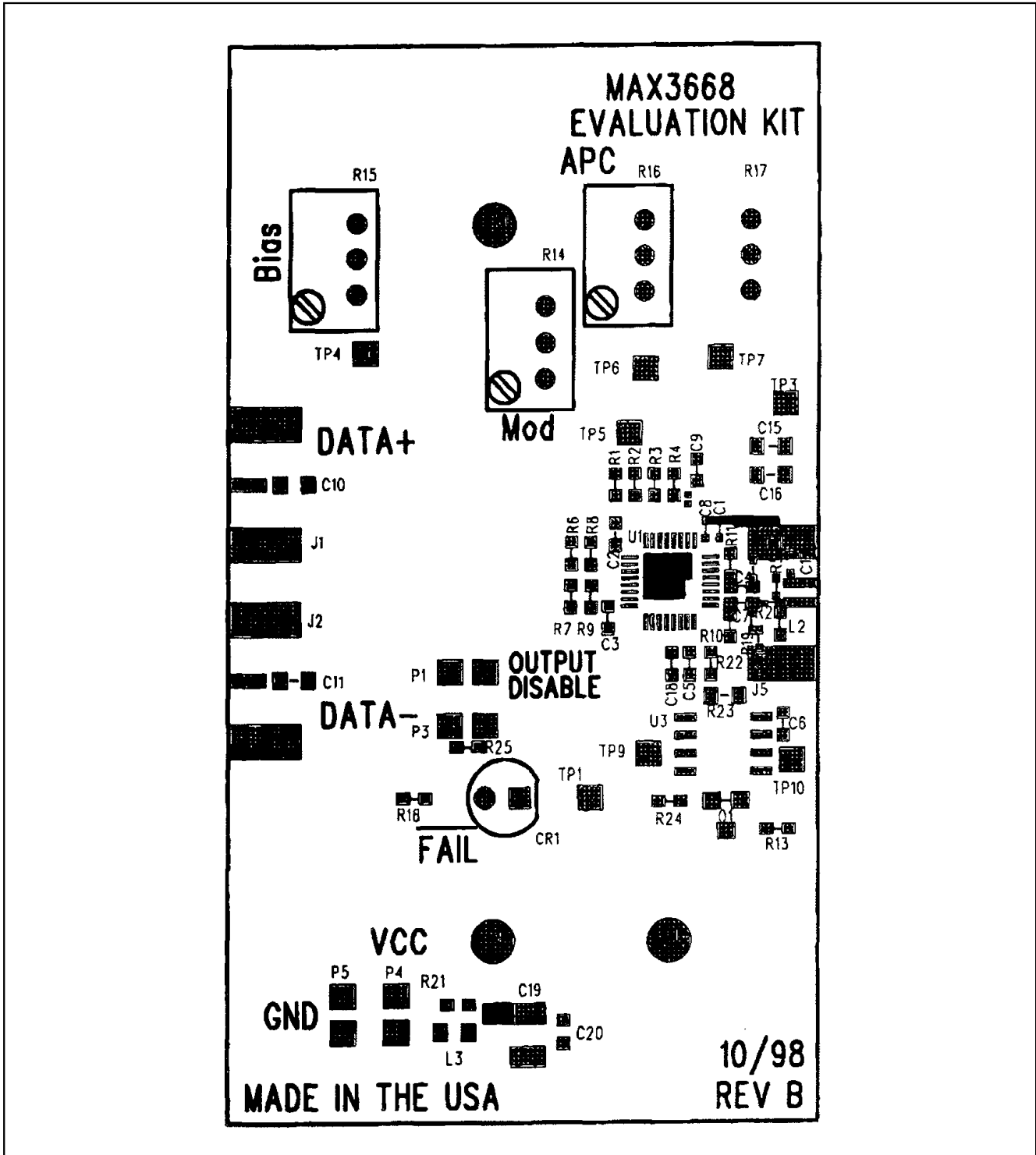

Figure 2. Expanded View of Component Placement

MAX3668 Evaluation Kit

Evaluates: MAX3668

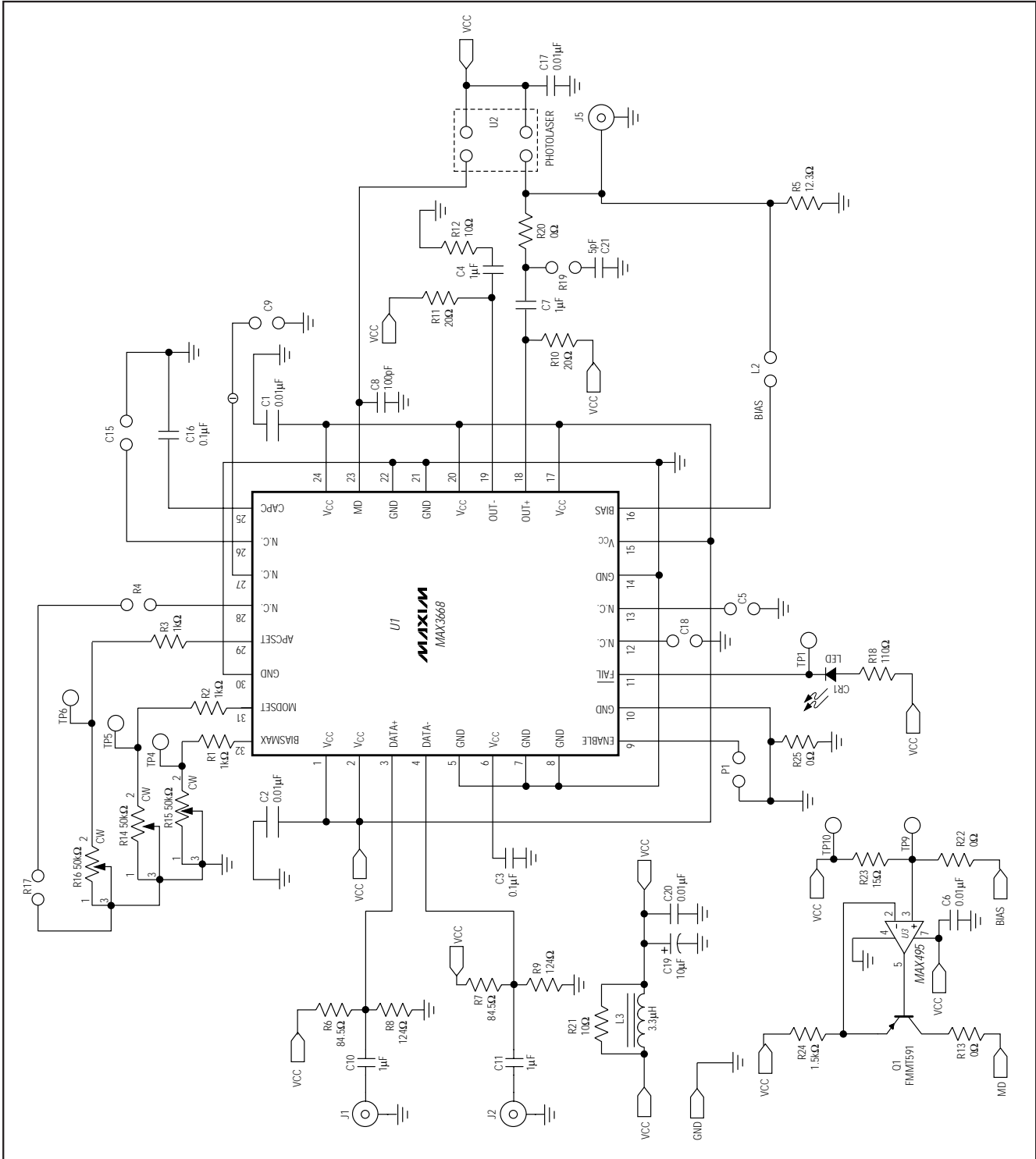

Figure 3. MAX3668 EV Kit Schematic—Electrical Configuration

MAX3668 Evaluation Kit

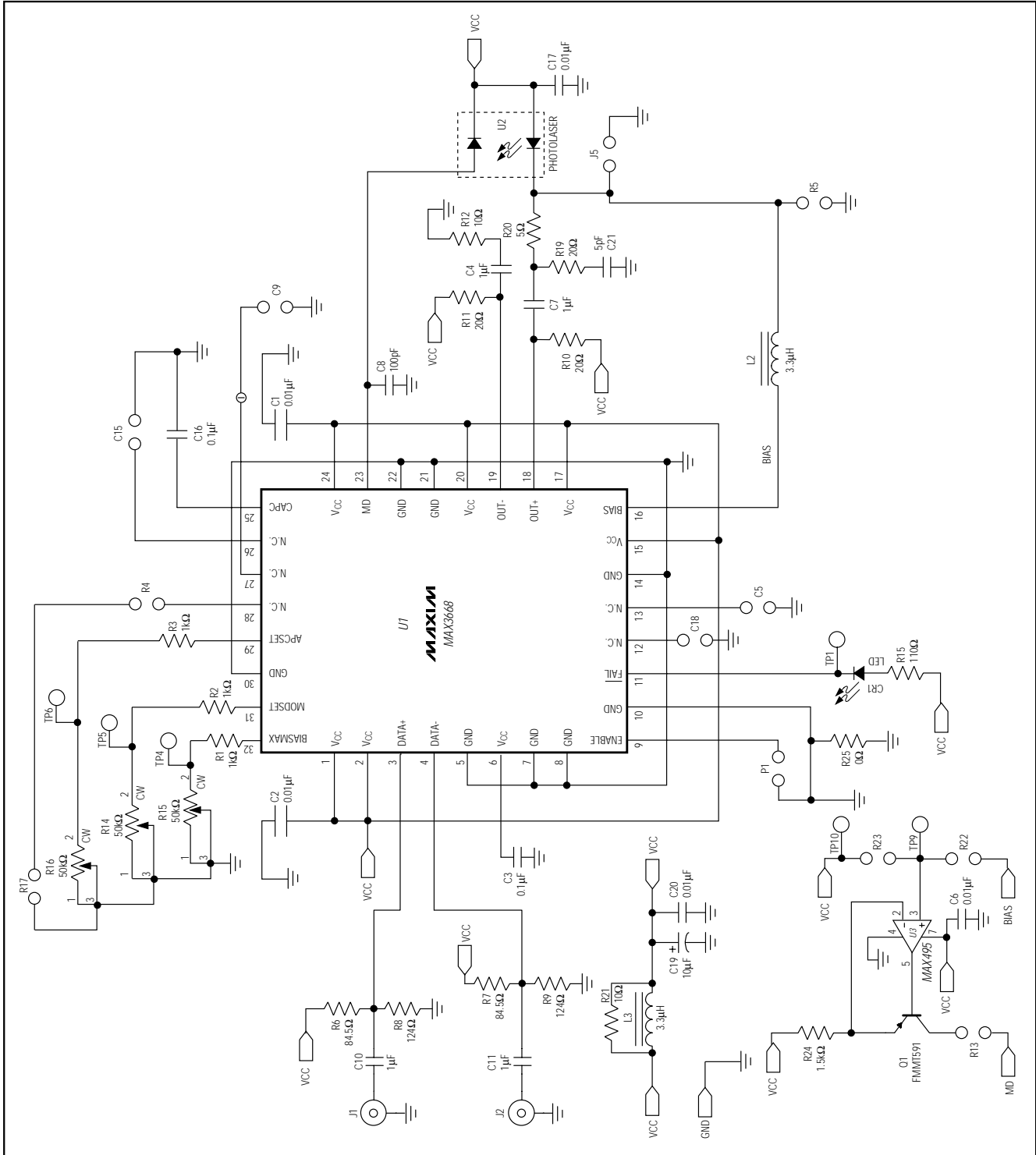

Figure 4. MAX3668 EV Kit Schematic—Optical Configuration

MAX3668 Evaluation Kit

Evaluates: MAX3668

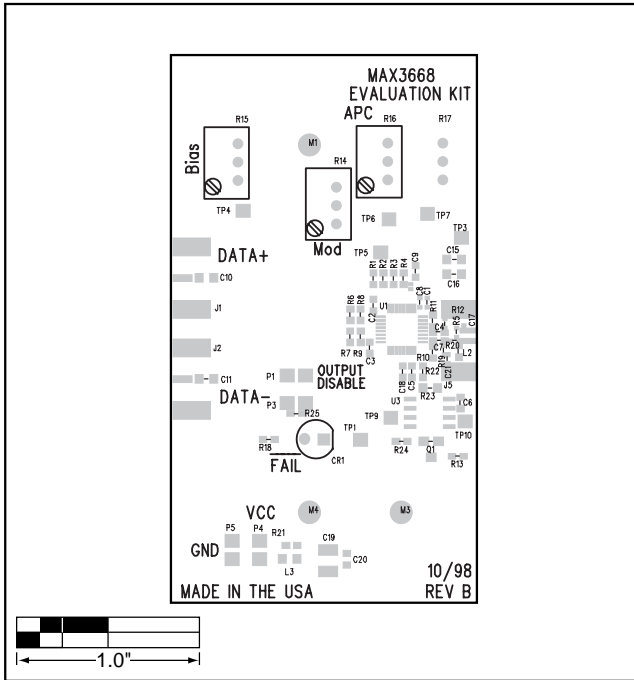

Figure 5. MAX3668 EV Kit Component Placement Guide—Component Side

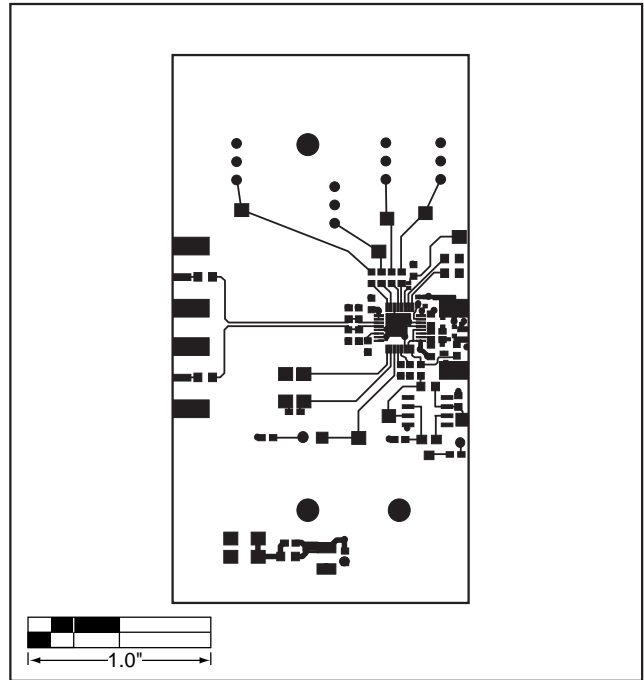

Figure 6. MAX3668 EV Kit PC Board Layout—Component Side



Figure 7. MAX3668 EV Kit PC Board Layout—Solder Side

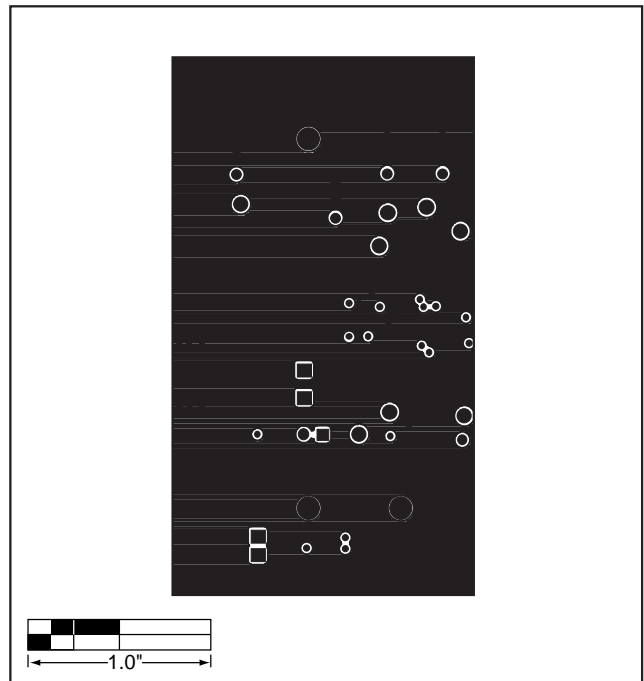

Figure 8. MAX3668 EV Kit PC Board Layout—Ground Plane

MAX3668 Evaluation Kit

Evaluates: MAX3668

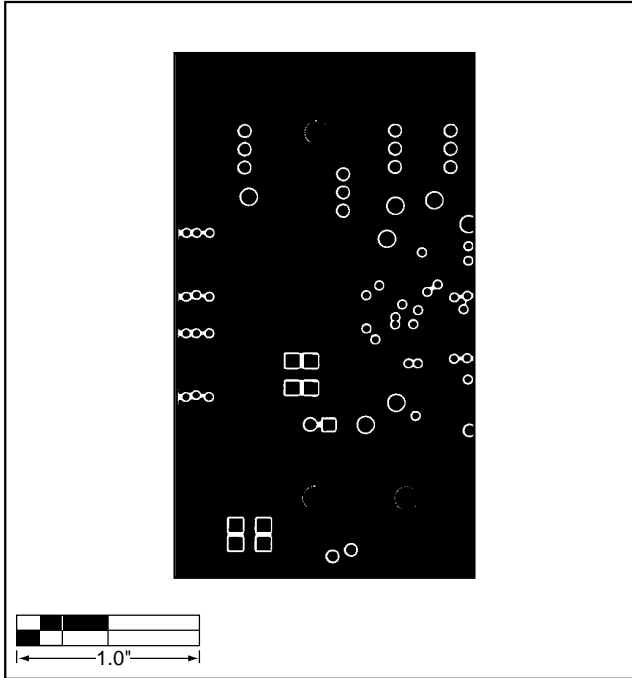

Figure 9. MAX3668 EV Kit PC Board Layout—Power Plane

Maxim cannot assume responsibility for use of any circuitry other than circuitry entirely embodied in a Maxim product. No circuit patent licenses are implied. Maxim reserves the right to change the circuitry and specifications without notice at any time.

8 _____ Maxim Integrated Products, 120 San Gabriel Drive, Sunnyvale, CA 94086 408-737-7600

© 1999 Maxim Integrated Products

Printed USA

MAXIM is a registered trademark of Maxim Integrated Products.